

4BTA3.9-G3

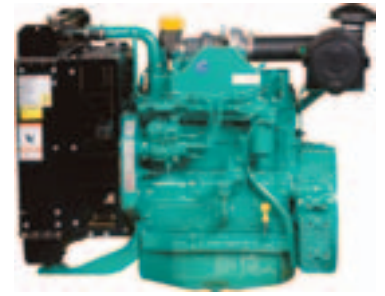

> Specification sheet

Our energy working for you.™



Description

The B3.9 has all the strength and reliability the genset industry has come to expect from the B Series range. The B3.9 features direct fuel injection, resulting in cleaner quieter and more fuel efficient performance.



This engine has been built to comply with CE certification.



This engine has been designed in facilities certified to ISO9001 and manufactured in facilities certified to ISO9001 or ISO9002.

Features

Coolpac Integrated Design - Supplied with cooling package and air cleaner kit for a complete power package.

Single Poly Vee belt drive for fan, alternator and water pump, with self-tensioning idler for minimum maintenance.

Stanadyne DB4 injection pump features advance mechanism for reliable cold starting.

Spin-on fuel filter and full-flow lubricating oil filter.

Top mounted Holset HX30 turbocharger for increased power, fuel economy and lower smoke and noise levels.

Service and Support - G-Drive products are backed by an uncompromising level of technical support and after sales service, delivered through a world class service network.

1500 rpm (50 Hz) Ratings

Gross Engine Output			Net Engine Output			Typical Generator Set Output					
Standby	Prime	Base	Standby	Prime	Base	Standby (ESP)		Prime (PRP)		Base (COP)	
kWm/BHP			kWm/BHP			kWe	kVA	kWe	kVA	kWe	kVA
81/108	73/97	RTF	78/105	70/94	RTF	30	38	28	35	RTF	RTF

1800 rpm (60 Hz) Ratings

Gross Engine Output			Net Engine Output			Typical Generator Set Output					
Standby	Prime	Base	Standby	Prime	Base	Standby (ESP)		Prime (PRP)		Base (COP)	
kWm/BHP			kWm/BHP			kWe	kVA	kWe	kVA	kWe	kVA
97/130	87/117	RTF	93/125	84/113	RTF	80	100	73	91	RTF	RTF

Our energy working for you.™

www.cumminsgdrive.com

©2007 | Cummins G-Drive Engines | Specifications subject to change without notice | Cummins are registered trademarks of Cummins Inc. (01/08) (GDSS103-RevA)



General Engine Data

Type	4 cycle, in-line, Turbo Charged
Bore mm	102 mm (4.02 in.)
Stroke mm	120 mm (4.72 in.)
Displacement Litre	3.9 litre (293.3 in. ³)
Cylinder Block	Cast iron, 4 cylinder
Battery Charging Alternator	65 amps
Starting Voltage	12 volt, 65 Amp negative ground
Fuel System	Direct injection
Fuel Filter	Spin-on fuel filters with water separator
Lube Oil Filter Type(s)	Spin-on full flow filter
Lube Oil Capacity (l)	10.9
Flywheel Dimensions	3/11.5

Coolpac Performance Data

Cooling System Design	Jacket Water After Cooled
Coolant Ratio	50% ethlene glycol; 50% water
Coolant Capacity (l)	15.0
Limiting Ambient Temp.**	50.0
Fan Power	0.6
Cooling system air flow (m ³ /s)**	48.0
Air Cleaner Type	Dry replaceable element with retriiction indicator

** @ 13 mm H₂O

Weights & Dimension

Length	Width	Height	Weight (dry)
mm	mm	mm	kg
1110	630	870	350

Fuel Consumption 1500 (50 Hz)

%	kWm	BHP	L/ph	US gal/ph
Standby Power				
100	81	108	21	5.5
Prime Power				
100	73	97	18	4.9
75	61	82	14	3.7
50	41	55	9	2.5
25	20	27	5	1.4
Continuous Power				
100	RTF	RTF	RTF	RTF

Cummins G-Drive Engines

Asia Pacific

10 Toh Guan Road
#07-01
TT International Tradepark
Singapore 608838
Phone 65 6417 2388
Fax 65 6417 2399

Europe, CIS, Middle

East and Africa
Manston Park Columbus Ave
Manston Ramsgate
Kent CT12 5BF. UK
Phone 44 1843 255000
Fax 44 1843 255902

Latin America

Rua Jati, 310, Cumbica
Guarulhos, SP 07180-900
Brazil
Phone 55 11 2186 4552
Fax 55 11 2186 4729

Mexico

Cummins S. de R.L. de C.V.
Eje 122 No. 200 Zona Industrial
San Luis Potosí, S.L.P. 78090
Mexico
Phone 52 444 870 6700
Fax 52 444 870 6811

North America

1400 73rd Avenue N.E.
Minneapolis, MN 55432
USA
Phone 1 763 574 5000
USA Toll-free 1 877 769 7669
Fax 1 763 574 5298

Our energy working for you.™

www.cumminsgdrive.com

©2007 | Cummins G-Drive Engines | Specifications subject to change without notice | Cummins are registered trademarks of Cummins Inc. (01/08) (GDSS103-RevA)

Ratings Definitions

Emergency Standby Power (ESP):

Applicable for supplying power to varying electrical load for the duration of power interruption of a reliable utility source. Emergency Standby Power (ESP) is in accordance with ISO 8528. Fuel Stop power in accordance with ISO 3046, AS 2789, DIN 6271 and BS 5514.

Limited-Time Running Power (LTP):

Applicable for supplying power to a constant electrical load for limited hours. Limited-Time Running Power (LTP) is in accordance with ISO 8528.

Prime Power (PRP):

Applicable for supplying power to varying electrical load for unlimited hours. Prime Power (PRP) is in accordance with ISO 8528. Ten percent overload capability is available in accordance with ISO 3046, AS 2789, DIN 6271 and BS 5514.

Base Load (Continuous) Power (COP):

Applicable for supplying power continuously to a constant electrical load for unlimited hours. Continuous Power (COP) in accordance with ISO 8528, ISO 3046, AS 2789, DIN6271 and BS 5514.

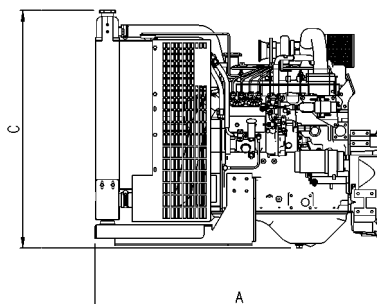
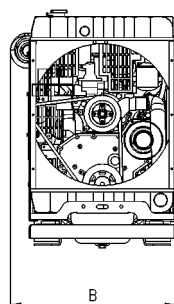

Fuel Consumption 1800 (60 Hz)

%	kWm	BHP	L/ph	US gal/ph
Standby Power				
100	97	130	25	6.5
Prime Power				
100	87	117	22	5.9
75	65	87	17	4.5
50	44	59	12	3.3
25	22	29	7	1.9
Continuous Power				
100	RTF	RTF	RTF	RTF

